

Electron Sources: an Introduction.

Fernando Sannibale and David Robin

**ALS Accelerator Physics Group
Lawrence Berkeley National Laboratory**

**Charged Particle Sources and Beam Technology – NEC 282
University of California, Berkeley
(October 2, 2007)**

Lecture Outline

- 1) Basic information. A brief review and some glossary.**
- 2) How to generate electrons.**
- 3) Characteristics of an electron source.**
- 4) Examples of existing sources.**
- 5) Performance limiting factors.**
- 6) An example of a new source scheme.**

1.

**Basic Information. A Brief Review
and Some Glossary**

Electron Story



Discovered by
J.J. Thomson in 1897



For the first time it was proved that the atom is not indivisible and that is composed by more fundamental components.

From the Greek ÈLEKTRON that means “Amber”.

Fundamental particle: lightest lepton.

$m = 9.1095 \times 10^{-31} \text{ kg}$ or $9.1095 \times 10^{-28} \text{ g}$
(1837 times lighter than a proton)

$e = 1.6022 \times 10^{-19} \text{ C}$ or $4.803 \times 10^{-10} \text{ esu}$

Where it can be found or generated

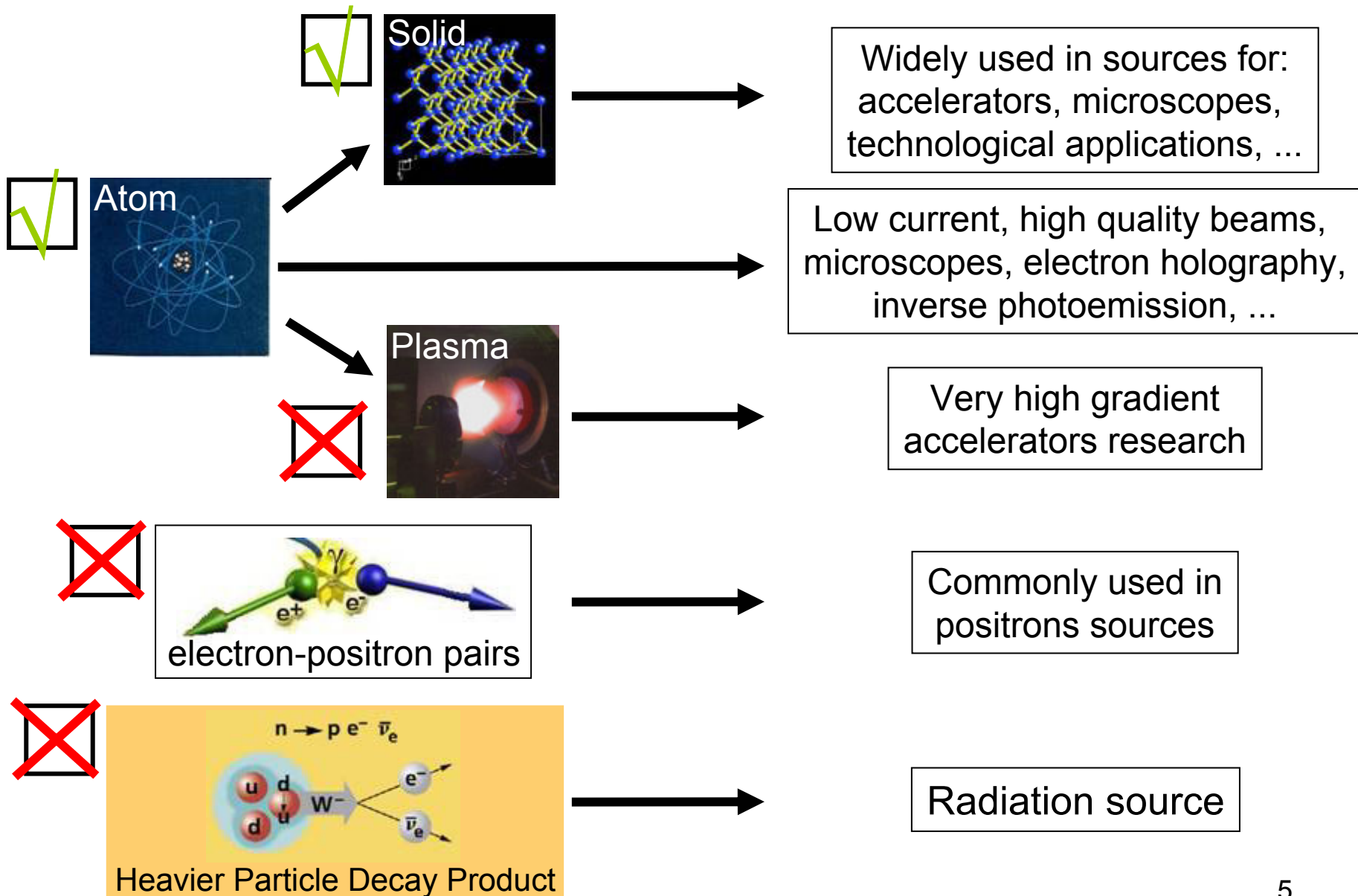

Two Families of particles: Fermions and Bosons

In quantum physics, all particles can be divided into two main categories according to their **spin**.

Particles with half-integer spin are called **fermions**, those with integer spin are called **bosons**.

Extremely important difference: only fermions, follow the **Pauli exclusion principle**:

“No two fermions may occupy the same state”.



- As a consequence, when more fermions are present in a system, they will occupy different energy levels.
- On the contrary, bosons will all occupy the lower energy level allowed by the system
- Because of the Pauli principle, the two categories follow different energy distributions:

Bosons

$$f_{BE}(E) = \frac{1}{Ae^{E/kT} - 1}$$

Bose-Einstein Distribution:

photons, mesons

Fermions

$$f_{FD}(E) = \frac{1}{e^{(E-E_F)/kT} + 1}$$

Fermi-Dirac Distribution:

electrons, protons, neutrons,...

Note that in the classical limit, both distributions are approximated by the Maxwell-Boltzmann distribution.

The Fermi Energy

~~Bose-Einstein Distribution for Bosons~~

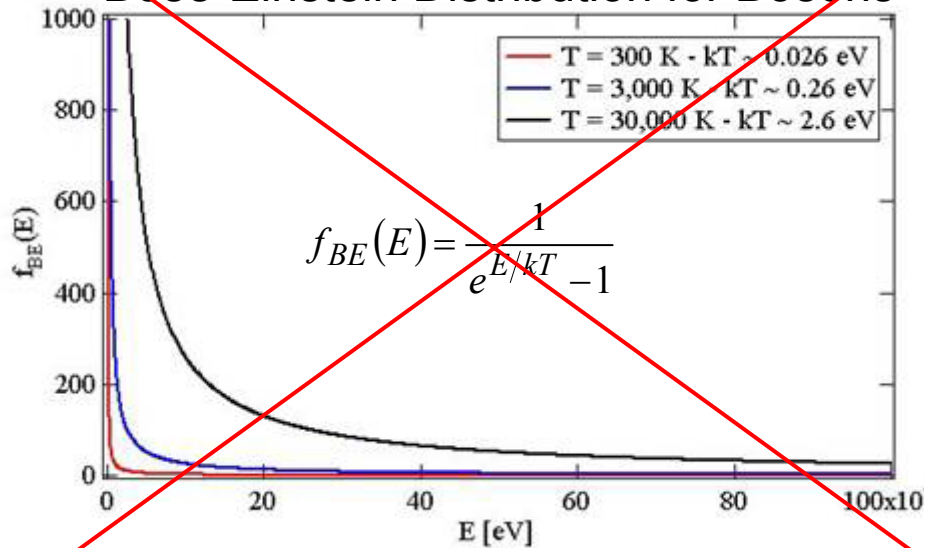

Fermi-Dirac Distribution for Fermions

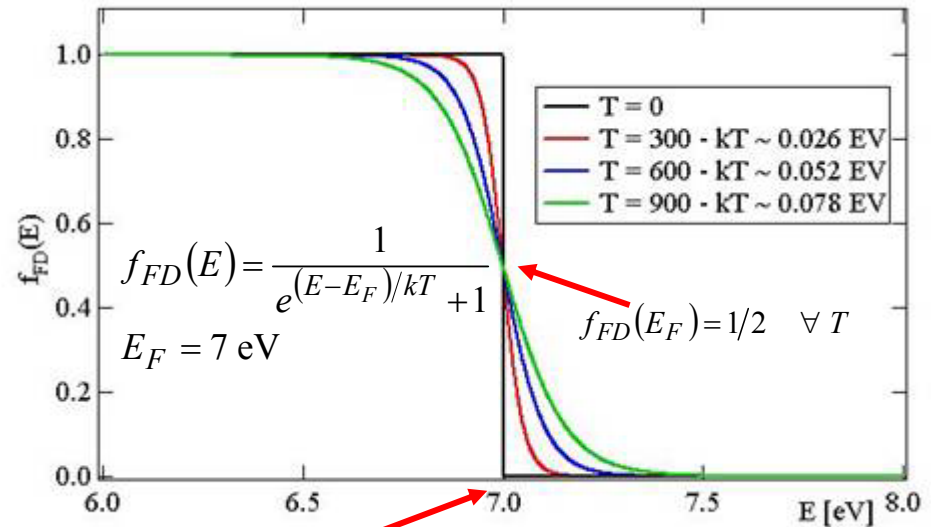

We are dealing with **electron sources**.
 Being electrons fermions (spin 1/2)
 we will concentrate our attention in the
 Fermi-Dirac distribution

Definition : In a system of fermions
 the **Fermi energy E_F** is the energy
 of the highest occupied state at
 zero temperature.

The system of fermions we are interested to is represented by **the electrons in a solid**.

The E_F value is a property of the particular material. Example: E_F for copper is 7 eV.

Solids and Work Function

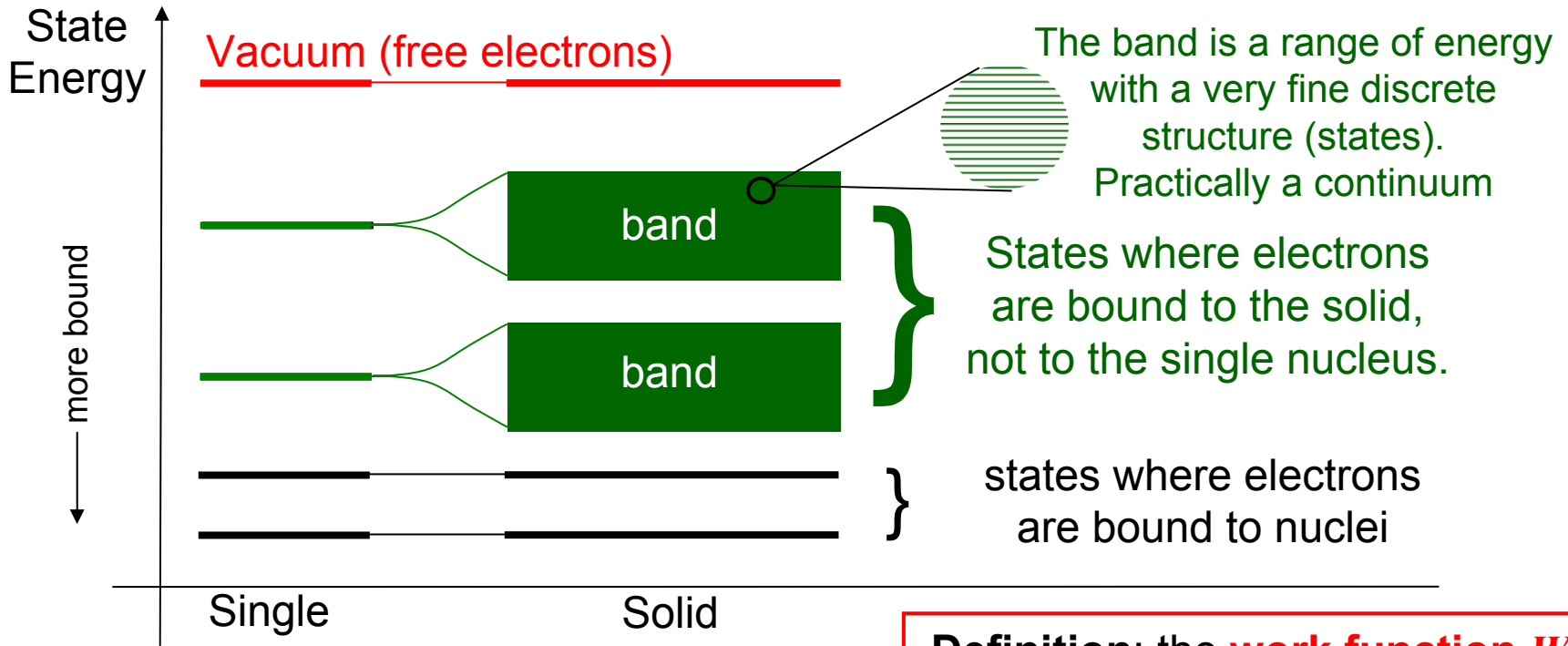

Definition: the **work function W_F** is the energy needed to bring an electron from the Fermi level to the vacuum level (a point at infinite distance away outside the surface).

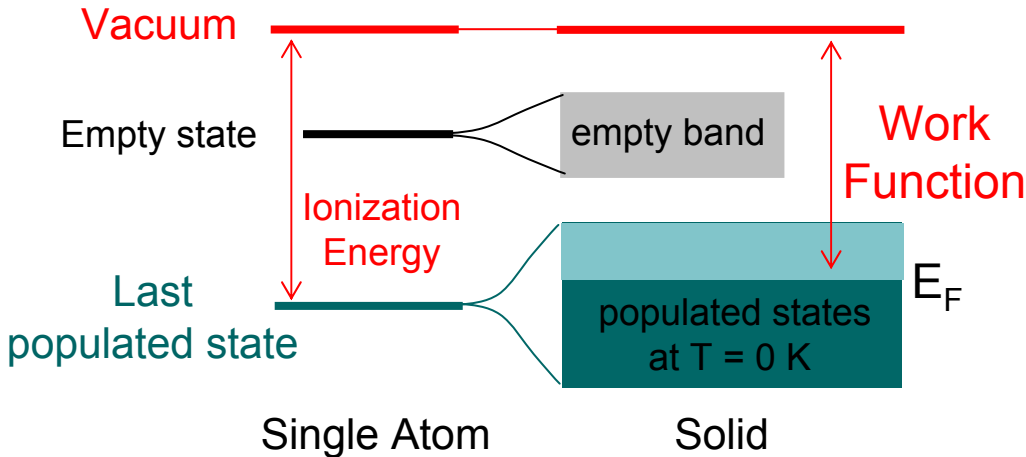

Example: for Copper (Cu)
 $E_I = 7.7\text{ eV}$
 $W_F = 4.7\text{ eV}$

Insulators and Conductors

Definition 1: In solids, the **valence band** is the band that at $T = 0$ K, is occupied by the highest energy electrons.

Definition 2: The **conduction band** is the higher energy band above the valence band.

INSULATORS:

- The valence and the conduction bands are separated by a **gap** with no allowed energy states.
- At $T = 0$ K, the valence band is completely filled with electrons.
- At $T = 0$ K, the conduction band is totally empty.

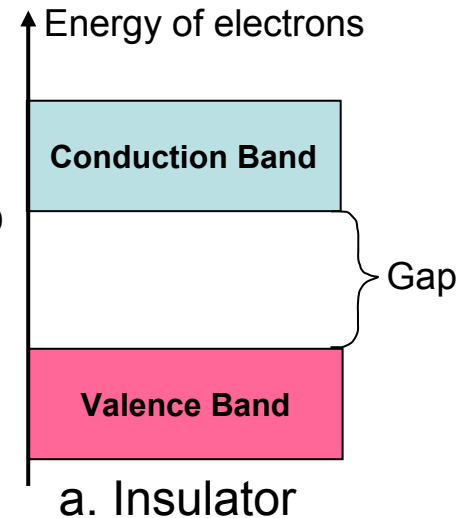

CONDUCTORS:

- The valence and the conduction bands **overlap**. The same band is now at the same time of valence and of conduction.
- The energy states in such a combined band are only **partially filled**.

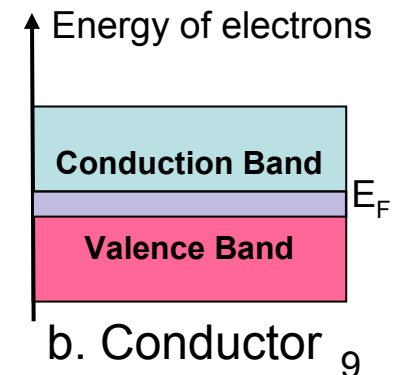

The Conduction Phenomenon

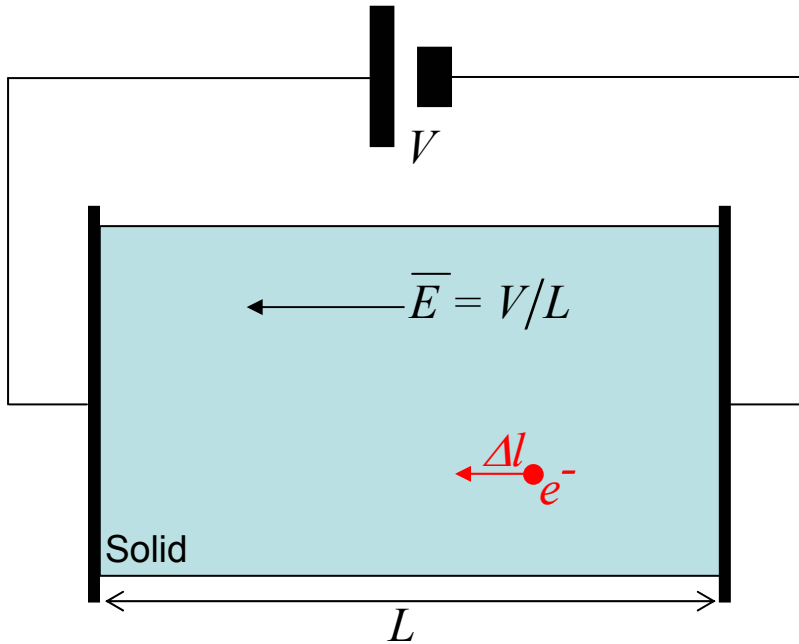

$$\text{Energy Variation} = \Delta W = e|\bar{E}|\Delta l = e\frac{V}{L}\Delta l$$

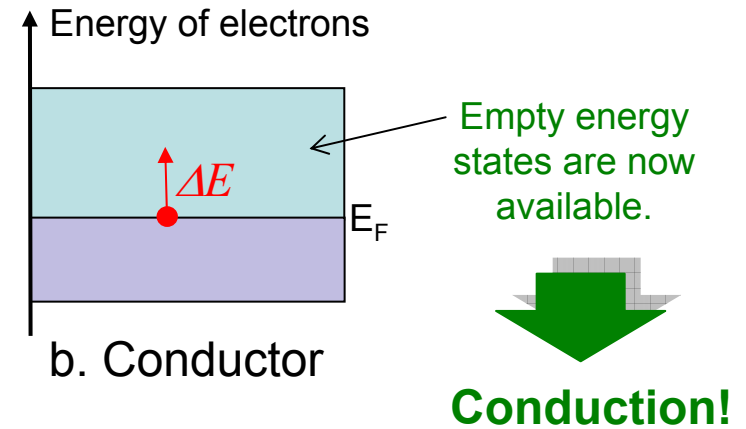
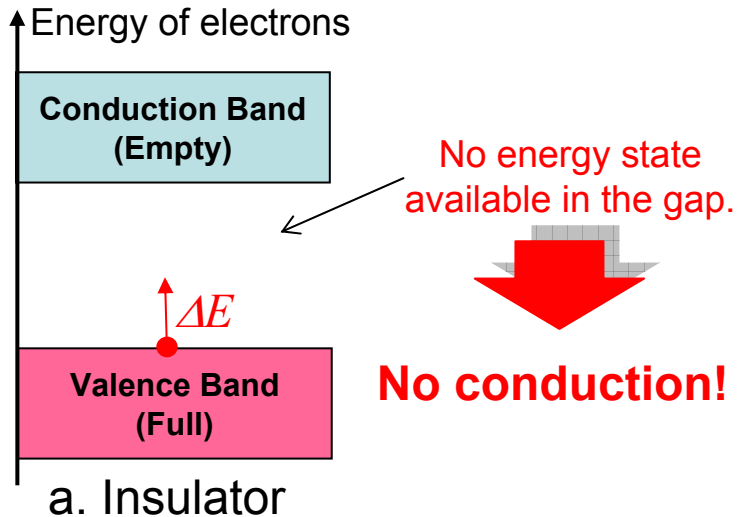

Semiconductors: a "Special" Insulator

Above absolute zero ($T = 0\text{K}$), the atoms in a solid start vibrating.

As a consequence, some of the electrons in the valence band scatter with the atoms gaining extra energy (the larger is T , the larger can be the extra energy).

If this extra energy is bigger than the energy gap between the bands in an insulator, the scattered electrons will "jump" from the valence to the conduction band.

As a consequence, when the temperature increases the solid experiences a **phase transition from insulator to conductor**.

A semiconductor is an insulator with a relatively **small gap** between the valence and conduction bands.

The gap is small enough that at room temperature ($T \sim 300\text{K}$), some of the electrons have been already scattered into the conduction band.

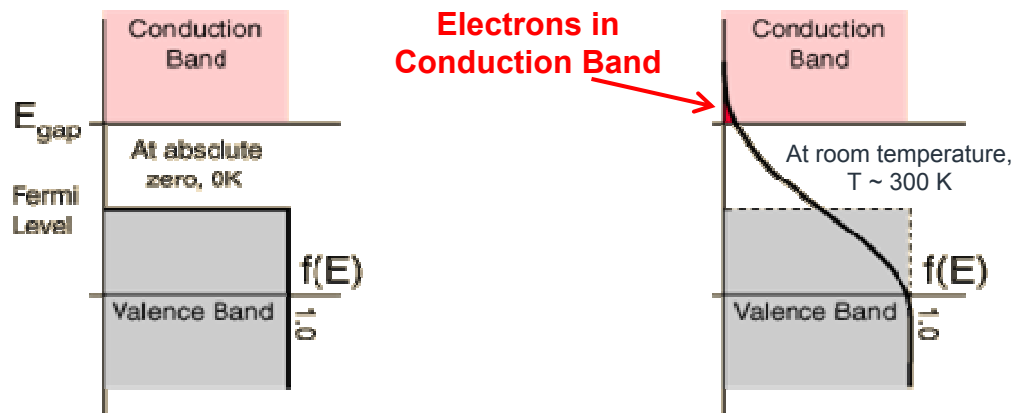

Silicon,
Germanium,

....

2.

How to generate electrons.

Thermionic Emission in Conductors

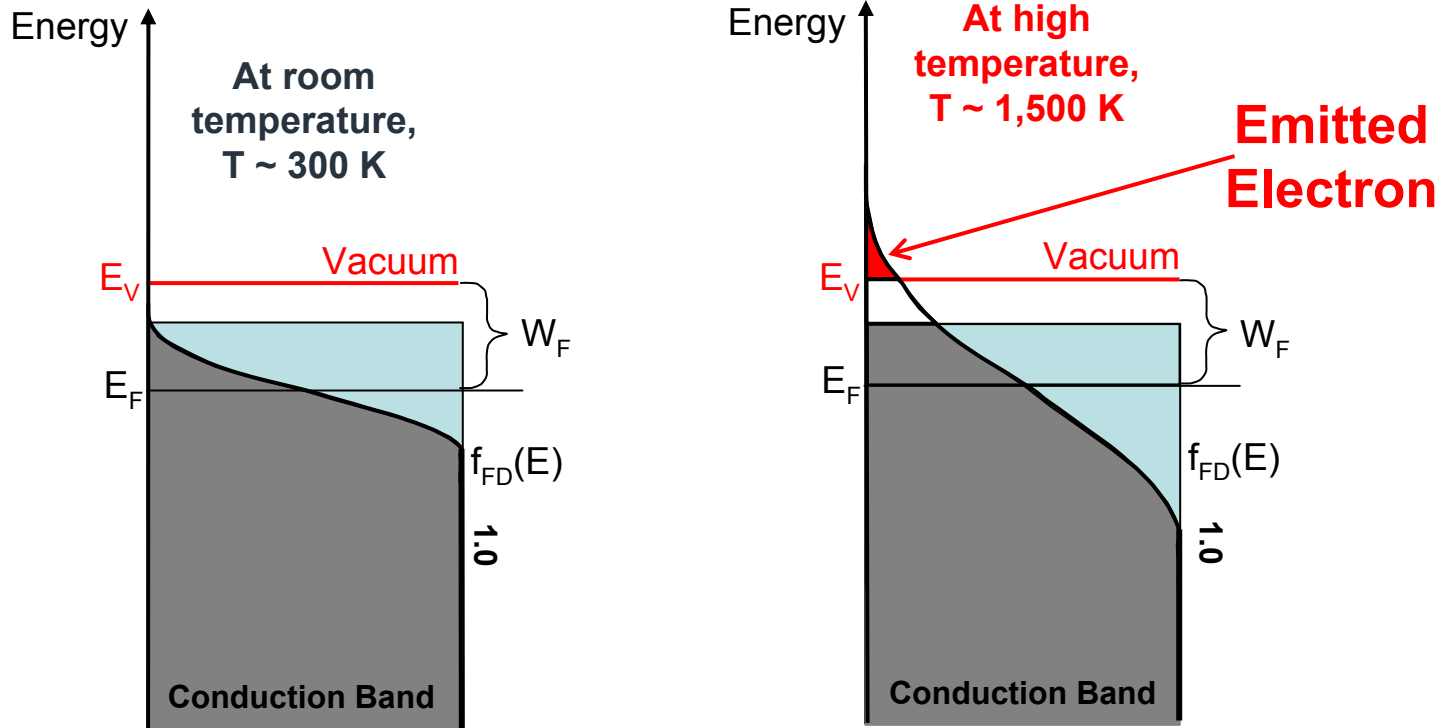

Thermionic emission was initially reported in 1873 by Guthrie in Britain.

Owen Richardson received a Nobel prize in 1928 "for his work on the thermionic phenomenon and especially for the discovery of the law named after him".



$$J = AT^2 e^{-w/kT}$$

$$A = \frac{4\pi mk^2 e}{h^3} = 1.20173 \times 10^6 \text{ Am}^{-2} \text{ K}^{-2}$$

$w \equiv$ work function

Photoelectric Effect

$$Photon\ Energy = E_{ph} = h\nu$$

photon frequency

Planck Constant = $6.626068 \times 10^{-34} \text{ m}^2 \text{ kg} / \text{s}$

$$\text{If } E_{ph} \geq W_F$$

$$T_{e^-} = E_{ph} - W_F$$

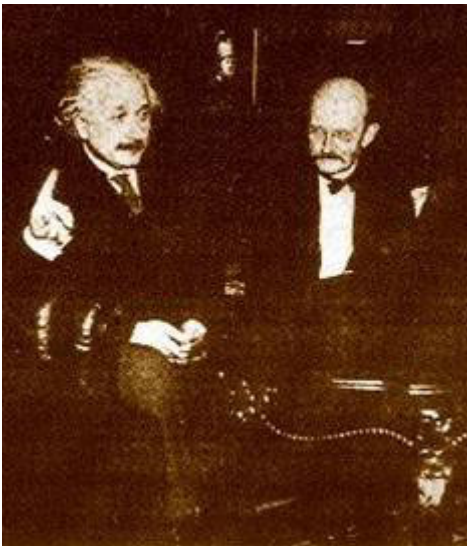
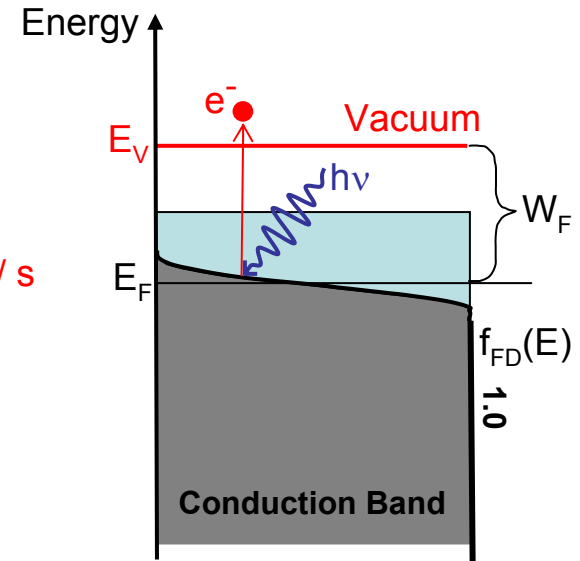

Albert Einstein received the 1921 prize in Physics for work that he did between 1905 and 1911 on the Photoelectric Effect.

Max Planck received the 1919 Nobel for the development of the Quantum Theory of the photon.

Field Emission

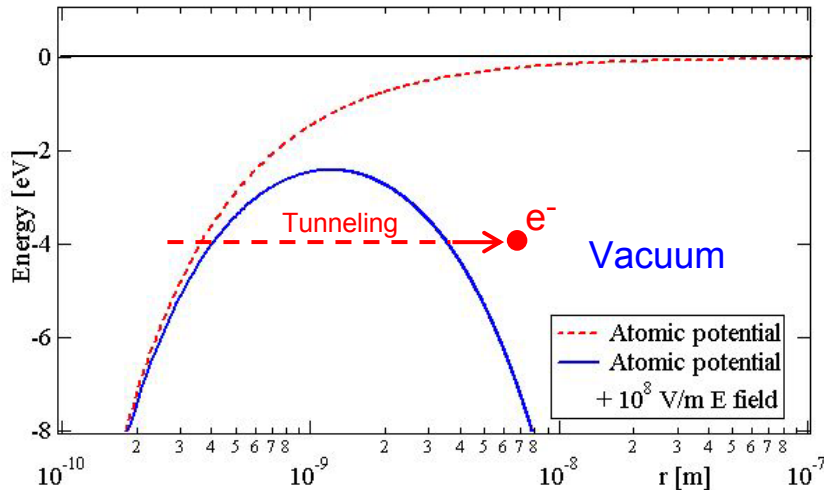

$$U_p = -\frac{1}{4\pi\epsilon_0} \frac{e^2}{r} + e|\overline{E}|r$$

$$|\overline{E}| = \text{constant}$$

Quantum tunneling is the quantum-mechanical effect of transitioning through a classically-forbidden energy state.

Field emission was first observed in 1897 by Robert Williams Wood.

But only in 1928, Fowler and Nordheim gave the first theoretical description of the phenomenon. It was one of the first application of the quantum mechanics theory.

Secondary Emission

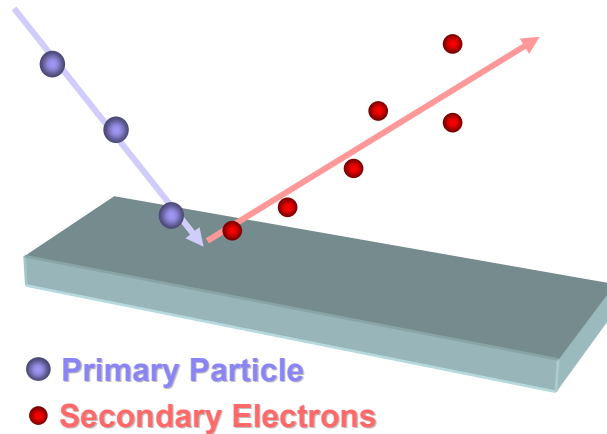

Primary Particles: photons, electrons, protons, neutrons, ions, ...

Physical Processes: ionization, elastic scattering, Auger electrons, bremsstrahlung and pair formation, Thomson scattering, ...

3.

Characteristics of an Electron Source.

The Typical Electron Source

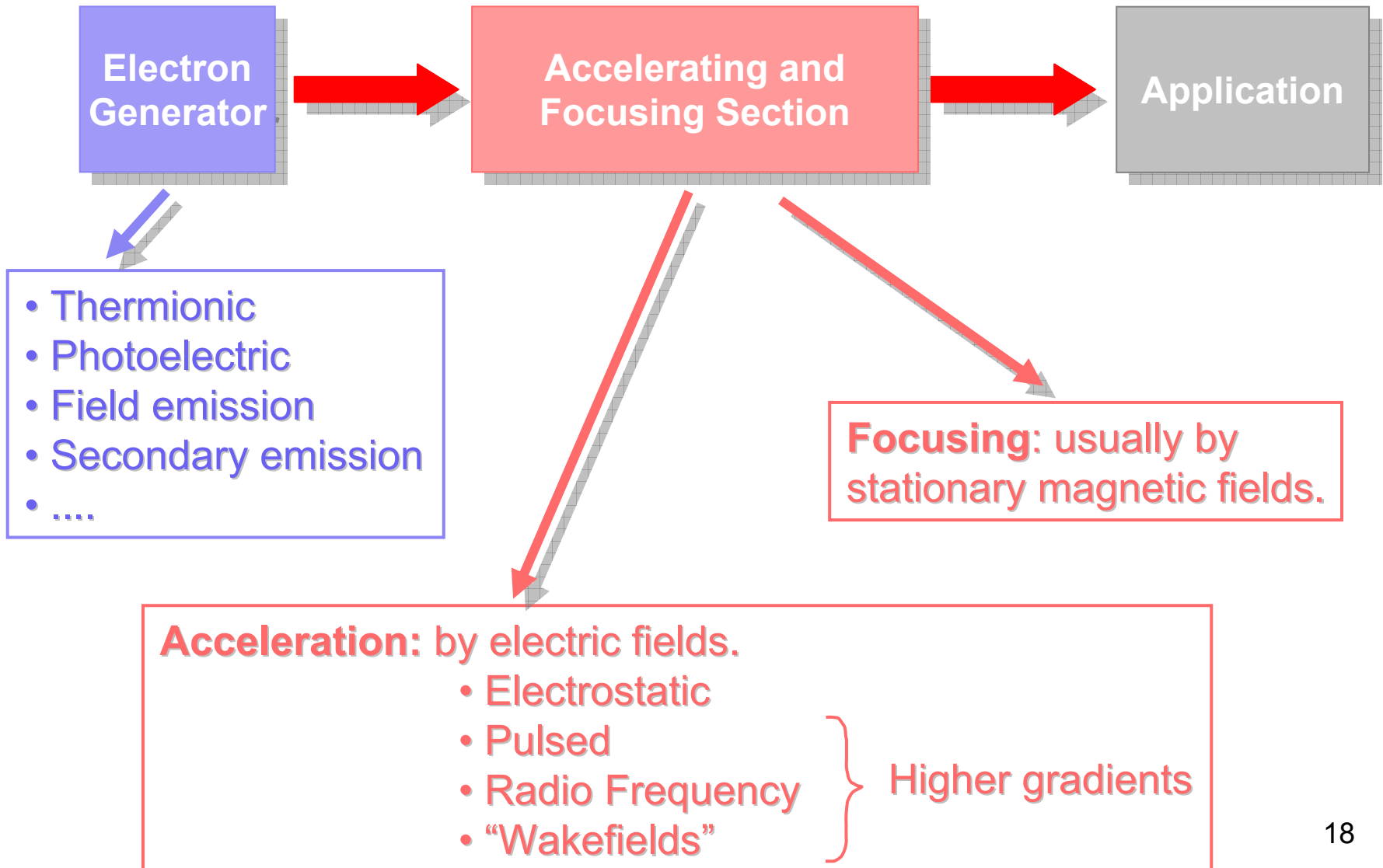

Electron Sources Main Parameters

Energy: from few eV to several MeV (~ GeV plasma source)

Energy Spread: from ~ 0.1 eV and up.

Current:

- Average: from less than a pA to several tens of A.
- Peak: from μA to thousands of A.

Time Structure:

DC

Pulsed: from single shot to hundreds of kHz

CW: from hundreds of MHz to several GHz

Bunch Length: from hundreds of fs to seconds.
Single electron.

Polarization: orientation of the electron spin

Coherence: in some (future) source schemes, the electrons need to be described in the quantum framework (wavepackets instead as of particles). For such sources the coherence between different wavepackets becomes an important parameter.

The Concept of Emittance

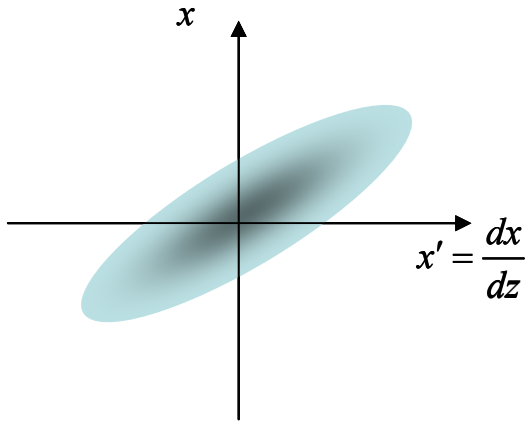

Emittance: quantity proportional to the volume of the phase space occupied by the beam particles

The emittance is generally a 6D quantity but quite often, the planes can be decoupled and the 2D cases can be investigated independently.

Liouville Theorem: in a Hamiltonian system (non-dissipative system) the emittance is conserved



For most applications, smaller emittances are preferred. It is very easy to increase this quantity, but very hard to preserve it!

Emittance and r.m.s. Emittance

A statistical definition: the r.m.s. Emittance:

$$\mathcal{E}_{rms} = \sqrt{\langle x^2 \rangle \langle x'^2 \rangle - \langle x x' \rangle^2}$$

- According to the Liouville theorem, in a Hamiltonian system the emittance is conserved. This is true even when the forces are nonlinear (space charge, nonlinear magnetic and/or electric fields, ...)

- This is **not** true for the case of the rms emittance.

In the presence of nonlinear forces the rms emittance is not conserved

- Example: *filamentation*. Particles with different phase space coordinates, because of nonlinear forces can move with different phase space velocity

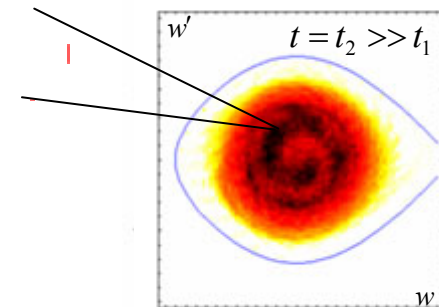
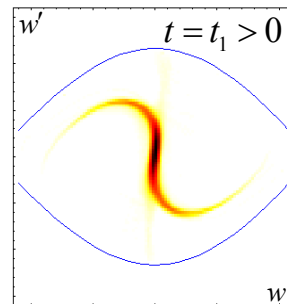
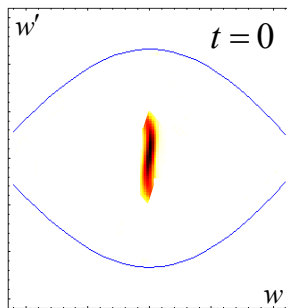

- The emittance according to Liouville is still conserved.
But the rms emittance **increases** with time.

Brightness and Degeneracy Factor

Brightness: density of particles in the phase space. I.e. number of particles per unit of phase space volume.



Heisenberg uncertainty principle: it is impossible to determine with precision and simultaneously, the position and the momentum of a particle. Applied to emittances:

$$\varepsilon_w \geq \lambda_c / 4\pi \quad w = x, y, z$$

$$\lambda_c \equiv \text{Compton wavelength} = h/m_0c = 2.426 \text{ pm for electrons}$$

This can be interpreted as the fact that the phase space volume occupied by a particle is given by: $(\lambda_c/2\pi)^3 = \text{elementary phase space volume}$

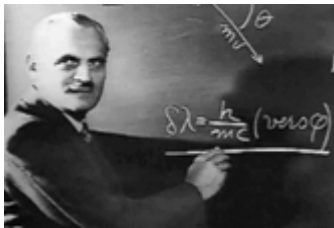

Degeneracy Factor, δ : if the phase space is expressed in elementary phase space volume units, the brightness becomes a dimensionless quantity δ representing the number of particles per elementary volume.

Because of the Pauli exclusion principle the **limit value of δ** is: infinity for bosons and **1 for non polarized fermions.**

Short pulses, low energy spread, small emittances, high current densities, all lead to a **high degeneracy factor.**

4.

Examples of Existing Sources.

Thermionic Electron Gun

LINAC LAB Gun (Fermi Lab):

$E = 100 \text{ keV}$

Current = 2 A max

Application: LINAC Injector



Current densities
 $\sim 10\text{-}100 \text{ A/cm}^2$

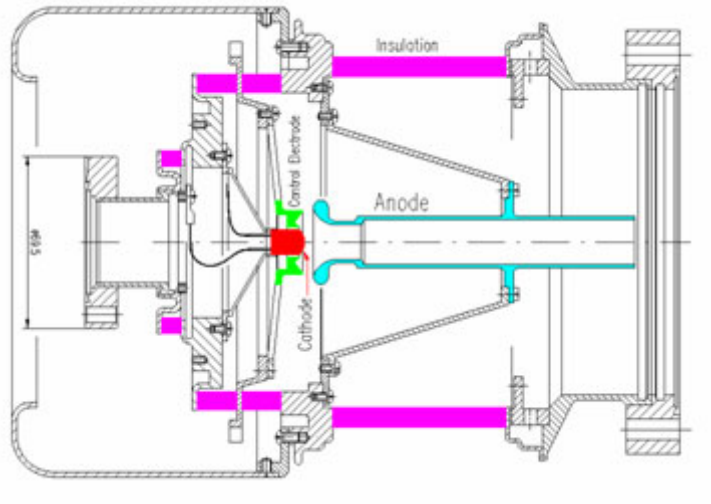

RF Gun with Photocathode

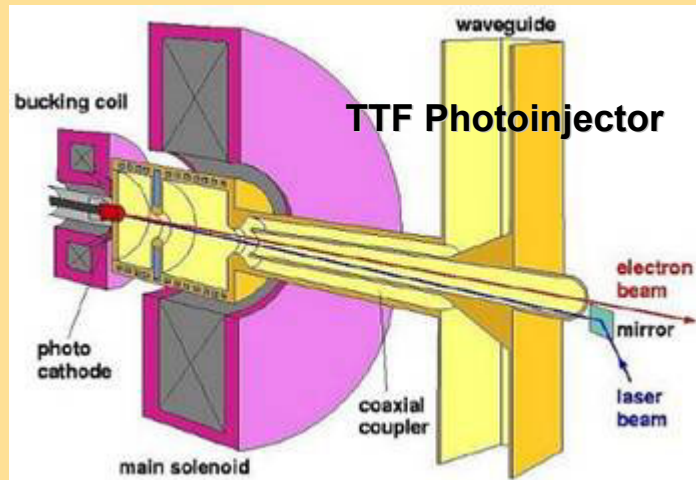

Peak current densities up to 10^5 A/cm^2

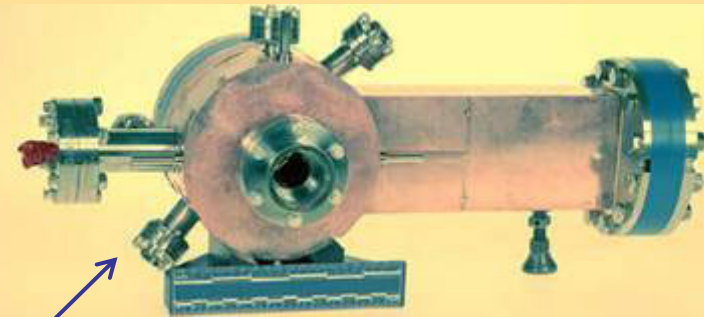

ATF (BNL) Gun III (LINAC Injector):

- Energy $\sim 2 \text{ MeV}$
- Normalized rms emittance of 2.6 mm mrad
- Charge of 1 nC
- Pulse length of 10 ps
- RF = 2856 MHz (100 MV/m)

Field Emission Electron Gun

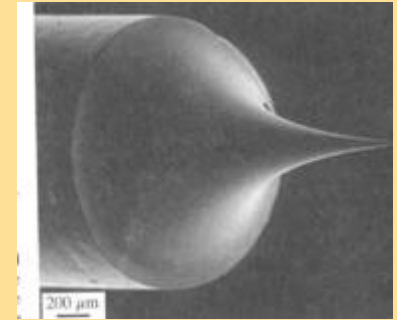
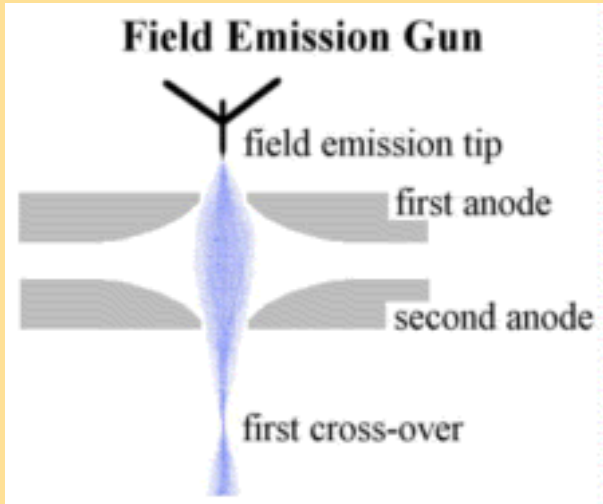

THERMO Electro Corporation:

- Field at the cathode tip $> 1 \text{ MV/cm}$
- 100 nm spot size at 5 nA sample current
- Average current density $\sim 50 \text{ A/cm}^2$
- Application: Electron microscopes

A Secondary Emission (SEM) Source

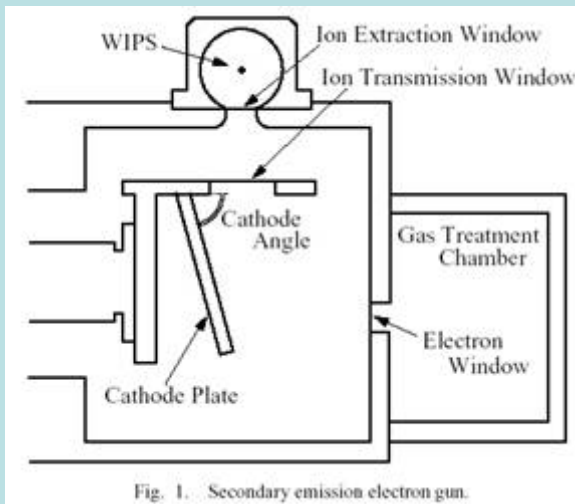

Fig. 1. Secondary emission electron gun.

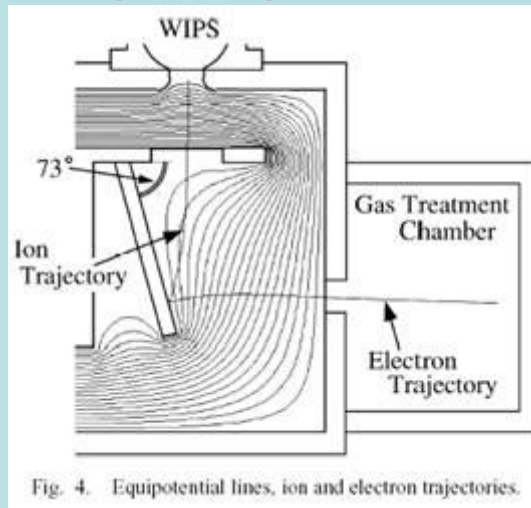

Fig. 4. Equipotential lines, ion and electron trajectories.

$E = 80 \text{ kV}$
 Current density: 6.4 mA/cm^2
 Ion source energy = 10 kV
 Very compact
 Application: gas treatment.

5.

Performance Limiting Factors.

Some Examples of Limitations

High power thermionic guns.

- Average Current. Limits in the cathodes current density.
- Cathode lifetime.
- Large cathode thermal emittance

RF Guns.

- Repetition Rate. Heat load in the RF structures limits.
- Max electric field. Field emission limits. Dark current.

Field emission guns.

- Max electric field at the tip. Limits in the minimum size of the tip.
- Intrinsic low average current.
- Tip damage, lifetime

Secondary Emission Gun.

- Low current densities.
- High energy spread, poor emittance.

The Ultimate Limit

Most of the edge electron beam applications (accelerators, free electron lasers, microscopes, inverse photoemission, ...) are limited by the performance of the electron gun in:

- **Emittance**
- **Energy spread**
- **Brightness**

**Degeneracy
factor δ**



- **Thermionic:** $\delta \sim 10^{-14}$
- **SEM:** $\delta < 10^{-14}$
- **Photo-RF guns:** $\delta \sim 10^{-12}$
- **Field emission:** $\delta \sim 10^{-5}$

The degeneracy factor inside a metal cathode is ~ 1 !!!

How do we loose all of that ?

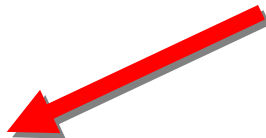

Extraction Mechanism



Coulomb interaction

6.

An Example of a new Source Scheme.

High Degeneracy Electron Source

M. Zolotorev, E. D. Commins, J. Oneill, F. Sannibale, W. Wan.
(Lawrence Berkeley National Laboratory and UCB)

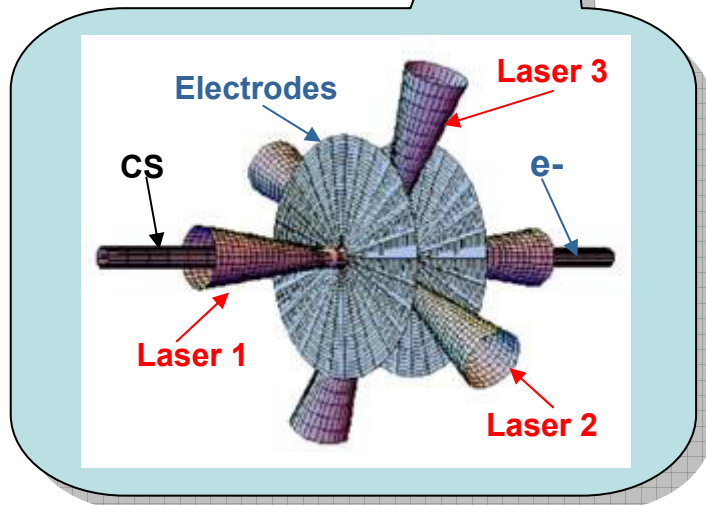
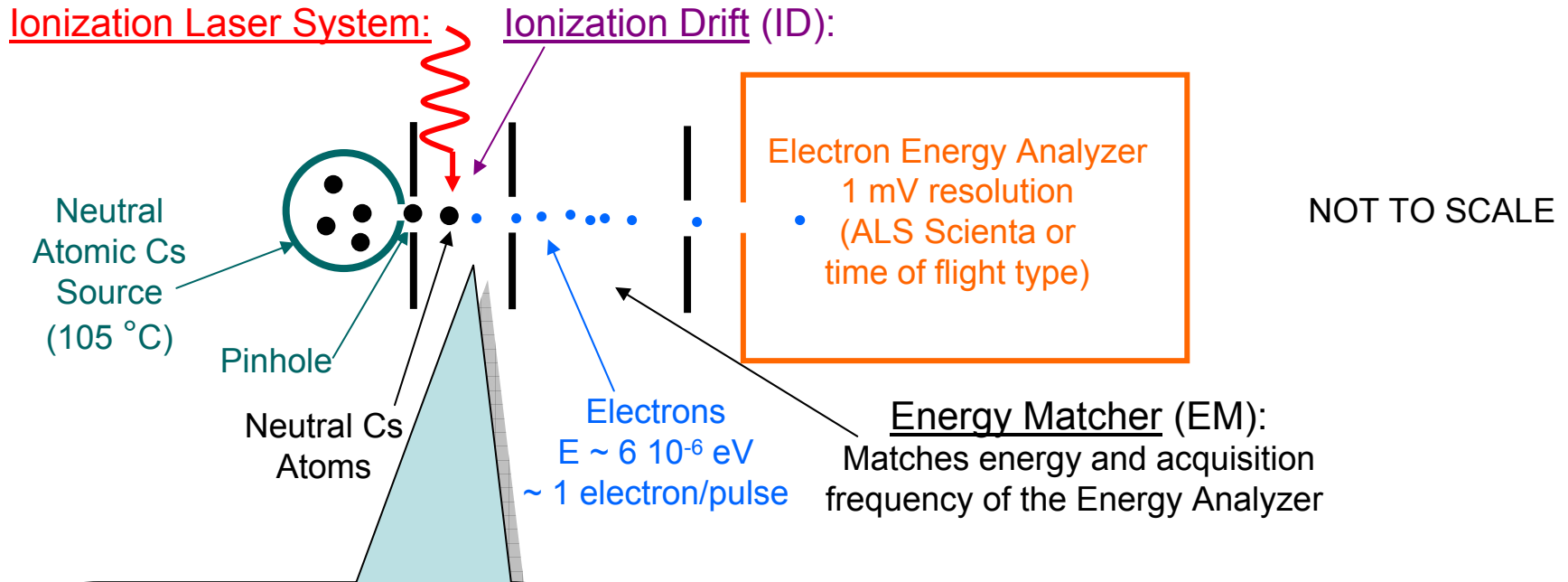

Timing:

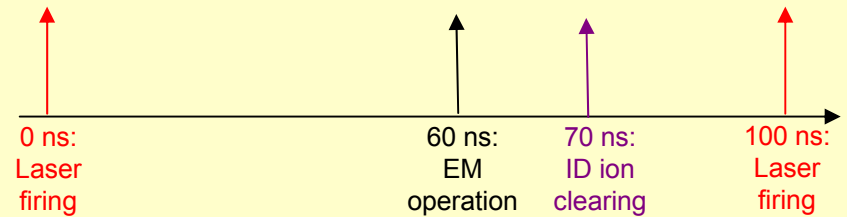

Fundamental Concepts

1) Atom Excitation. In the interaction region defined by the overlap of three lasers (2 CW and one pulsed), we excite on average one alkali atom per laser pulse to a very high Rydberg level ($n \sim 800$). The electron in the excited atom will have a total energy close to zero and will start to drift away from the ion on a Kepler-like orbit.

2) Waiting Period. After the laser pulse, we wait the time necessary (~ 40 ns) for the electron to arrive at the apogee of the orbit where its kinetic energy is practically zero ($\sim 10^{-5}$ eV) and we apply a short pulsed voltage to finally ionize the atom and to give the electron some kinetic energy (~ 1 eV) for leaving the interaction region area.

3) Electron Acceleration. In this step, the electron is accelerated up to the energy required by the application and leaves the gun.

4) Ion Clearing. After the electron acceleration, we apply a “cleaning” field in order to remove the residual ion before the beginning of the following cycle. In this way we avoid that the residual ion will interact with the electron produced in the next pulse.

The application of all such concepts allows to eliminate the Coulomb interaction between electrons (a single electron per cycle is produced) and to properly control the interaction between the electron and ions (parent and residual ones).

The degeneracy factor for this source is expected to be: $\delta \sim 0.5$

If the source is operated at 10 MHz repetition rate, can produce an average current of ~ 1 pA with densities of up to $\sim 10^4$ A/cm².

Main applications include Angstrom resolution scanning microscopes, electron holography, inverse photemission, ...

Proof of Principle Experiment at LBNL

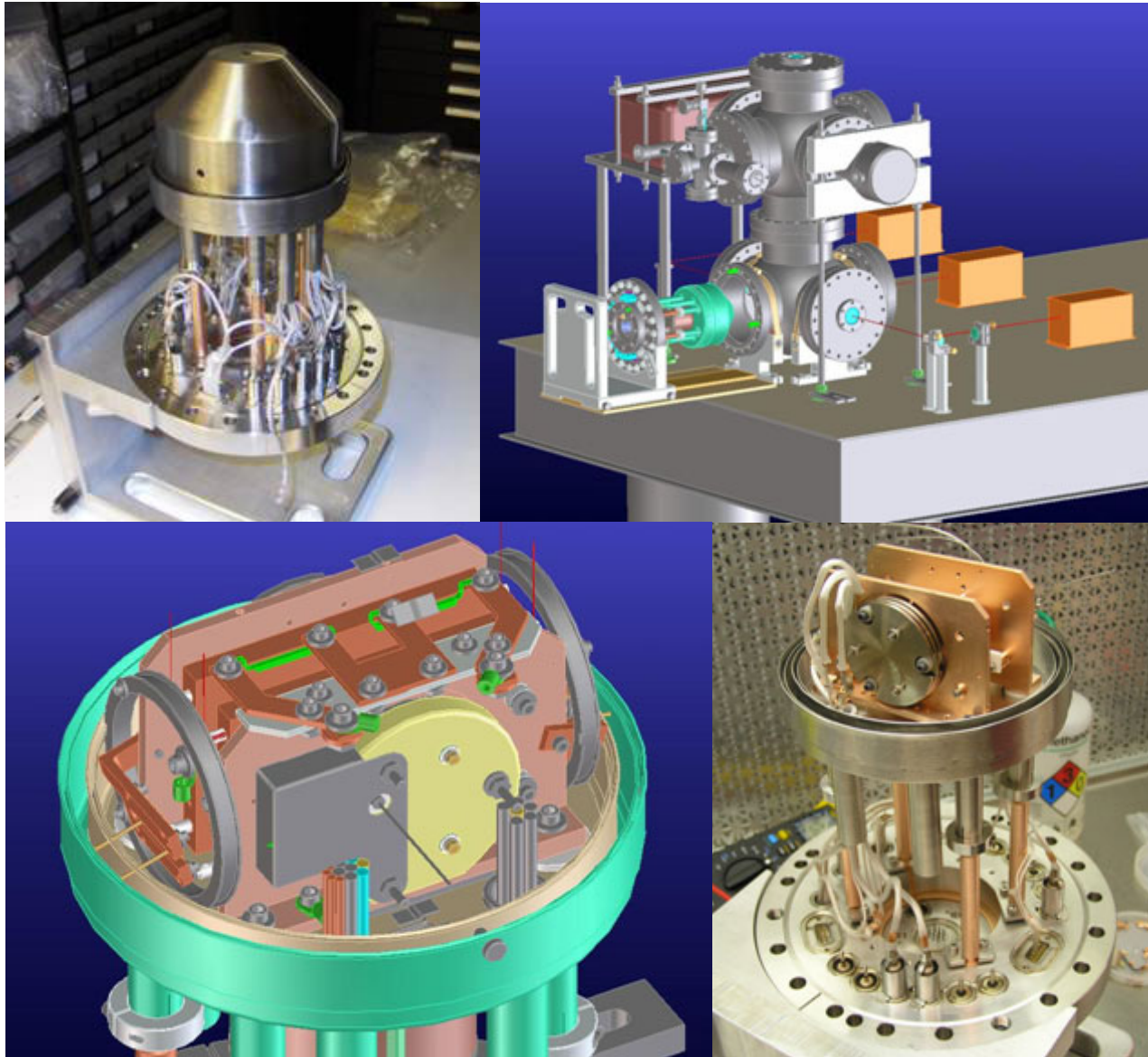

Construction finished, first results in the next few months